

Delaney

TECHNOLOGIES INC

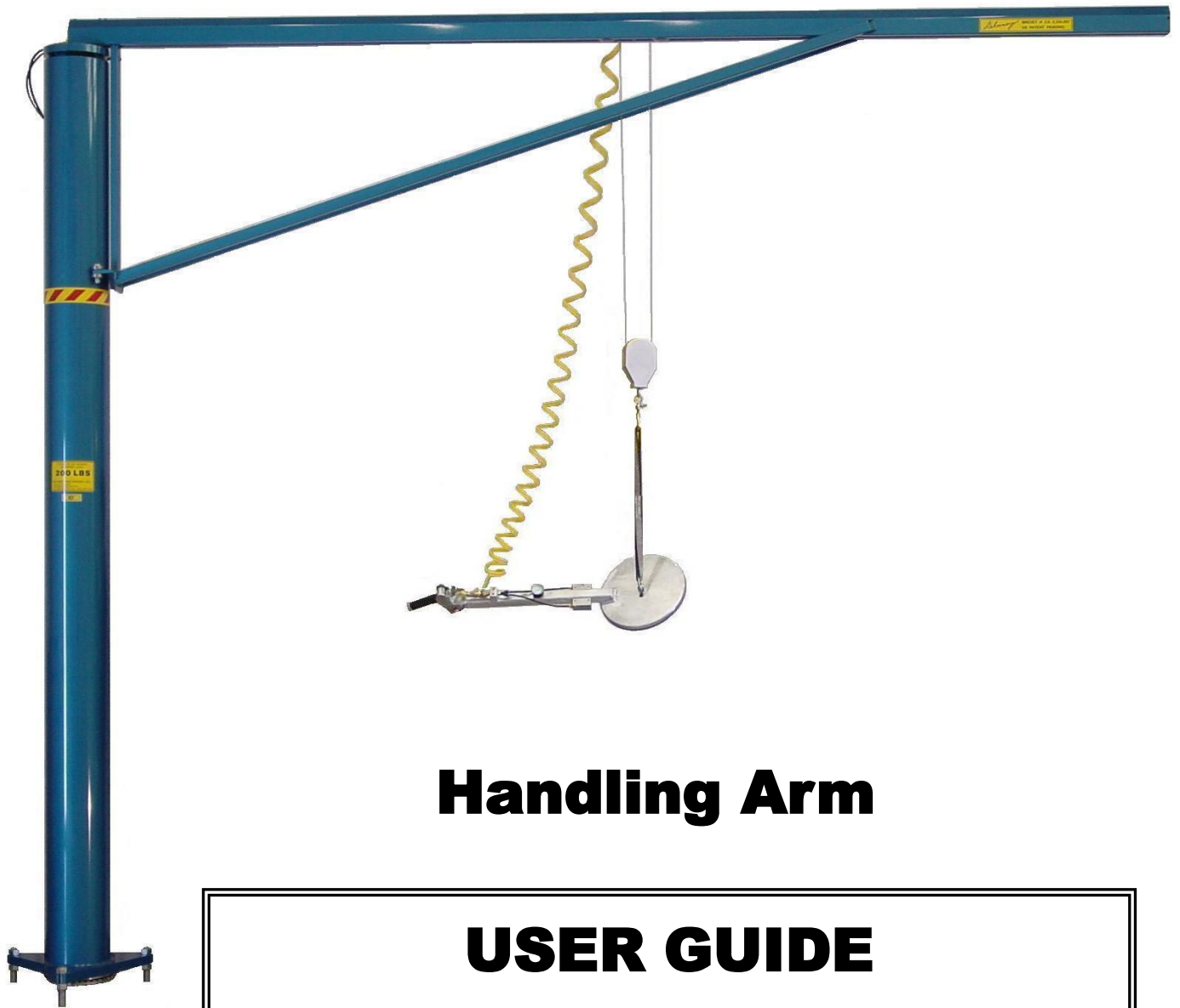

Handling Arm

USER GUIDE

Table of Contents

1. Installation Procedure.....	1
2. Cable Replacement Procedure	10
3. Contact Us.....	15

Installation Procedure

1. Determine the position of the handling arm.

The handling arm can be located anywhere within an 11 foot radius from the center of the material sheet positioned on the machine table.

Things to consider when determining the position :

- Material bundle positions
- Passage ways
- Ceiling clearances
 - Ducts
 - Pipes
 - Ventilation units
- Columns
- Access way to the machine
- Fork lift access

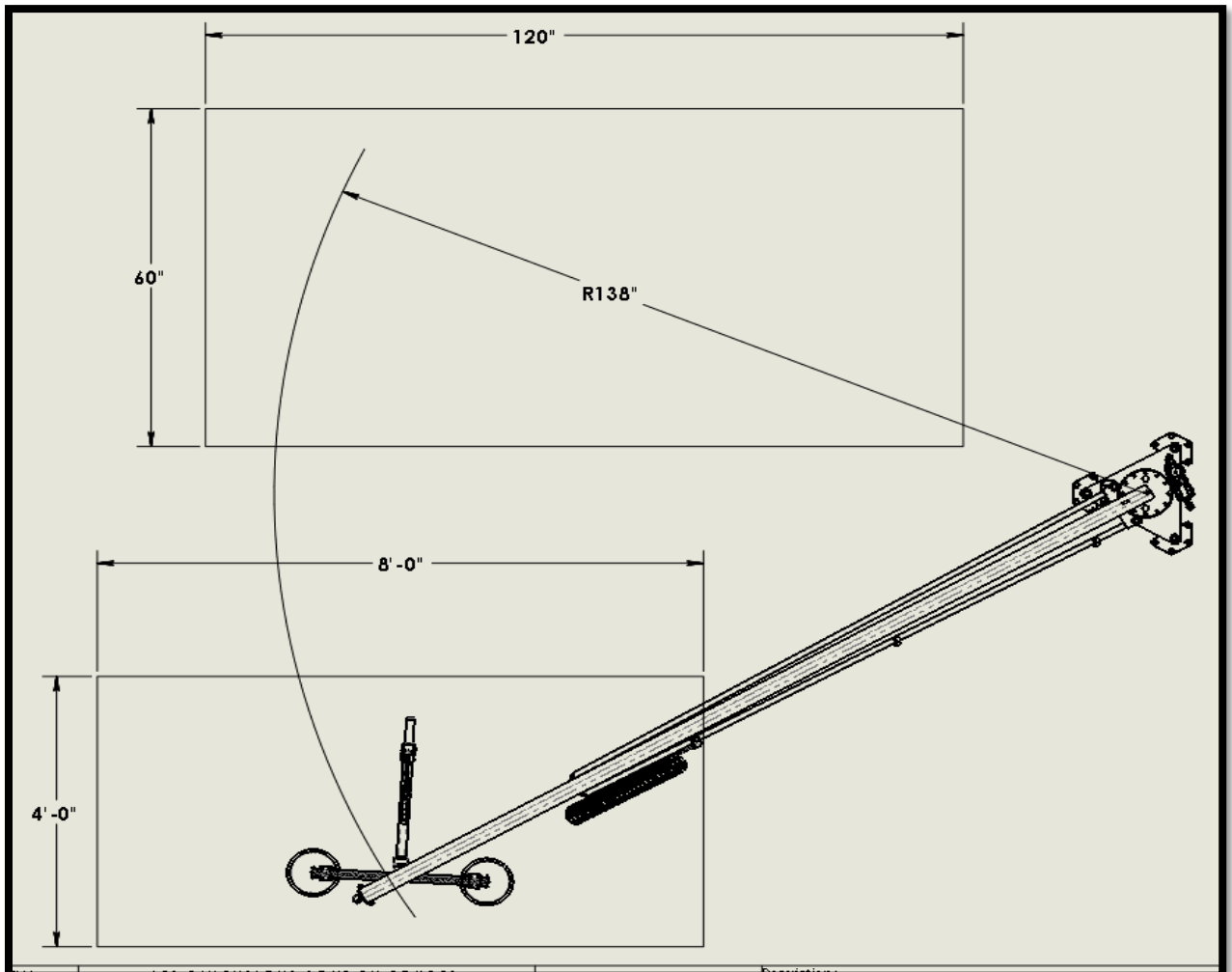

Layout Example

2. Installation of the Column.

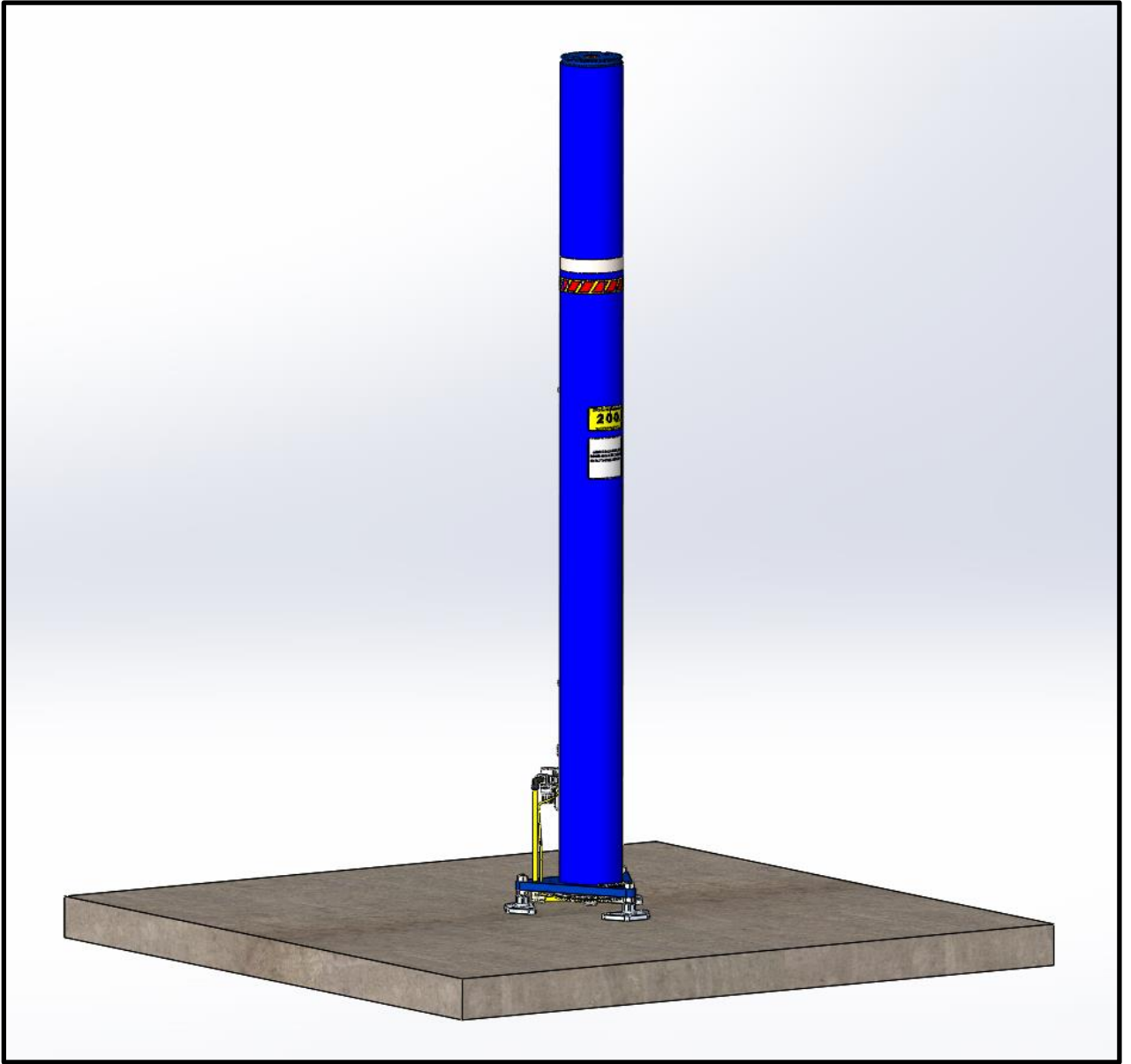

Bring the base of the column close to its intended position.

Remove the transport tube and bracket by removing the two ½-13NC bolts, unwinding the cable and carefully pulling the tube out of the column.

Be careful not to damage the cable in the process.

Leave the eye bolt in place.

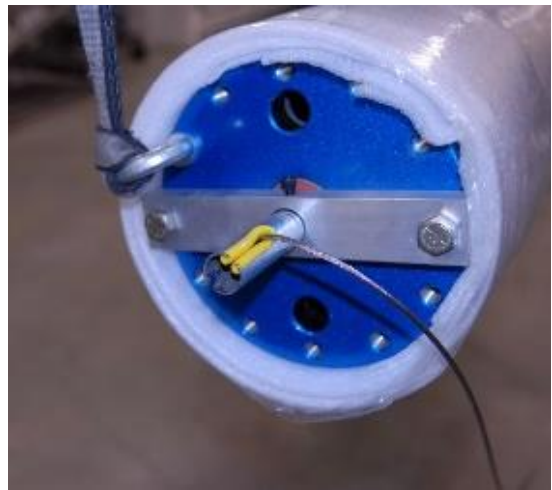

Run a sling through the eye bolt on top so that the ends can be attached to the fork of a forklift.

Use a clamp to prevent the sling from sliding off the end of the fork while lifting the column.



Lift the column up on its 3 Aluminium feet.

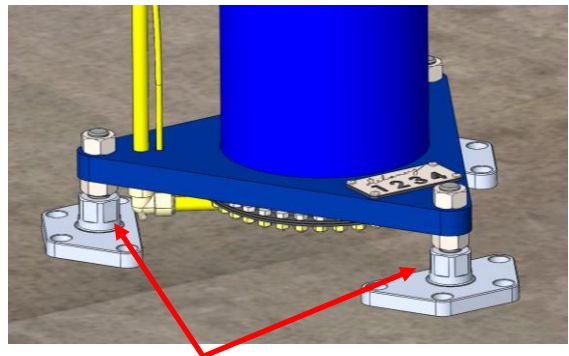
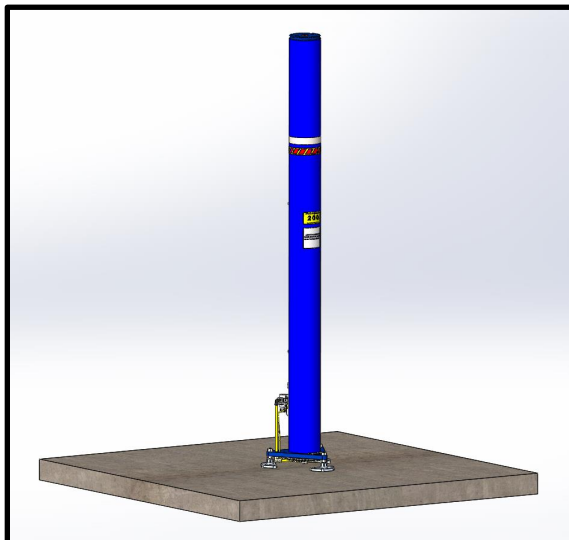

Level the column by adjusting (Turning) the aluminium feet.
This MUST be done Before anchoring.

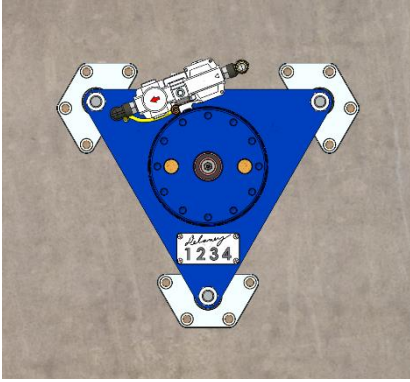

Once the column
is standing,
Remove the eye
bolt from the top.

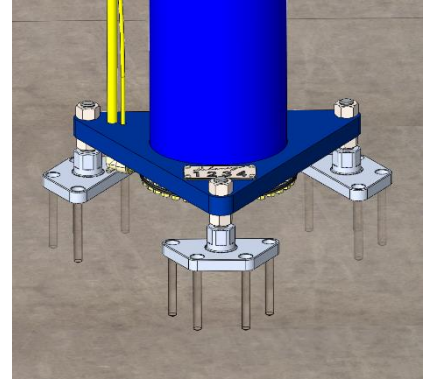

Orient the Aluminium retaining Plate as shown (Above Left) and Drill the 12 Holes (1/2" Dia. X 4" Deep) making sure that the plate doesn't move after the first hole is drilled.
(To clear the Triangular Base, the drill bit should be 10" lg.)

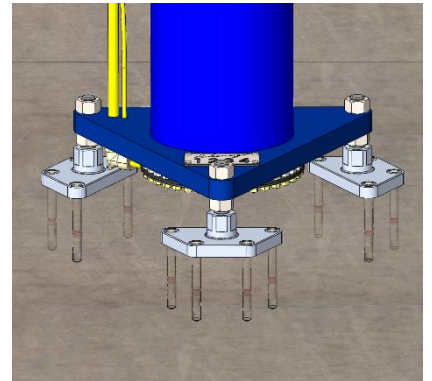
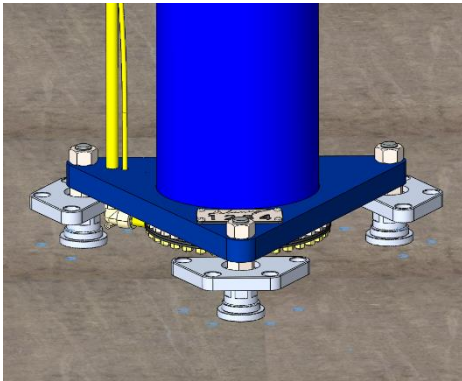

Remove cement dust from under the Aluminium retaining Plates and the holes before inserting the anchors.
Insert the 12 Anchors and tighten them to 30 Nm (22 FT-LB).

3. Installation of the Horizontal Beam

- a) Hold the beam horizontally with a fork lift.



- b) Thread the wire through the pivot bushing, around the pulley and down between the diagonal braces.



- c) Attache the hoses to the diagonal brace. The manifold bracket should be approximately 20" from the end or as best suited for the operation. Evenly distribute the clamps along the brace with the last one 6" away from the bearings at the column.



- d) Lift the horizontal beam 2 inches above the top of the column pulling the slack from the cable as you lift.
- e) Position and lower the pivot bushing onto the bearing at the top of the column.

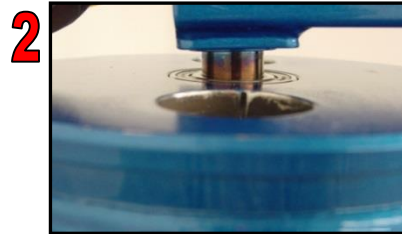
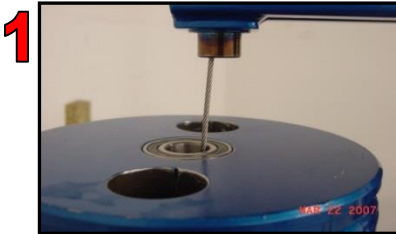

- f) Adjust and tighten the lock screw on the vertical brace at the top of the column leaving a maximum gap of 1/16".



- g) Insert and adjust the rotation friction brake under the angle support and between the 2 bearings. Tighten the set screw so that the beam rotates freely when pushing on the braces near the column and stays in place when letting it go.



h) Thread the wire through the pulley buggy and pulley block.

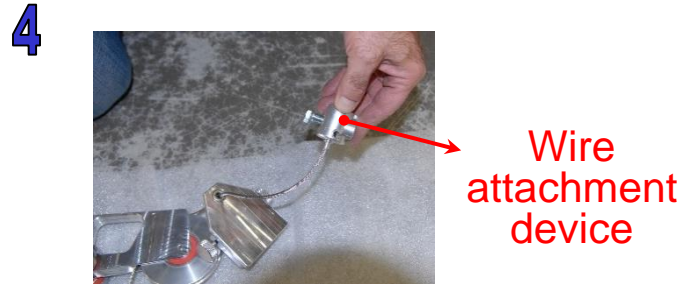
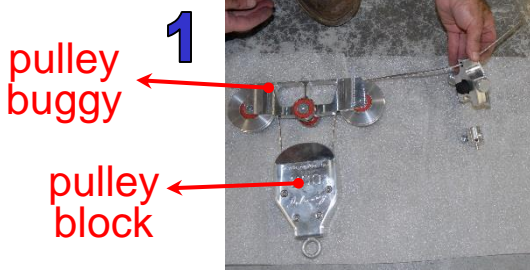

i) Insert the buggy into the horizontal beam and secure the end cap to the beam using the knurled knobs.



J) Adjust the wire length so that the pulley block is between the diagonal braces at their lowest point.



K) Hang the suction device on the pulley block and connect the air hoses.

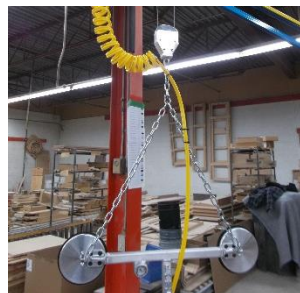

4. Air Supply

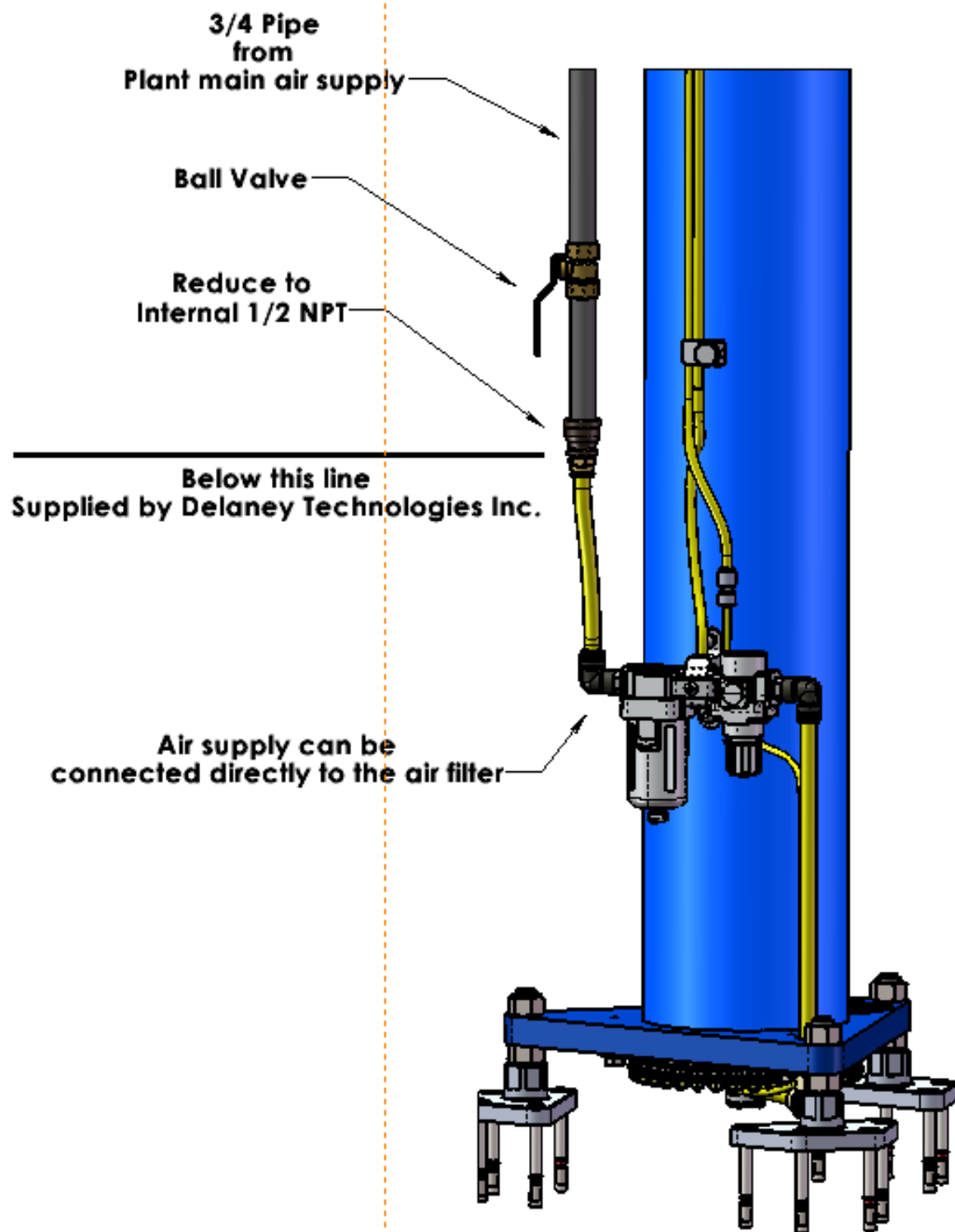

Scale :	Weight :	Description :
1:6	n/a	Pneumatic Connections
By:	Material :	
June 29, 2018	DELANEY TECHNOLOGIES INC.	Page : 7

5. Adjustments :

Downward speed: You can adjust downward speed by changing the outlet pressure on the regulator located near the post footing. The lower is the pressure, the slower it gets.

Upward speed: You can adjust Upward speed by restricting the stroke of the Control button, using the set screw passing through it as a stop.

Still position: If the device tends to move up or down by itself, turn the adjustment button both ways until you obtain the device to stay still. If the still position is difficult to obtain, it's better to be always moving upward, so it will simply return to its rest position.

Control lever

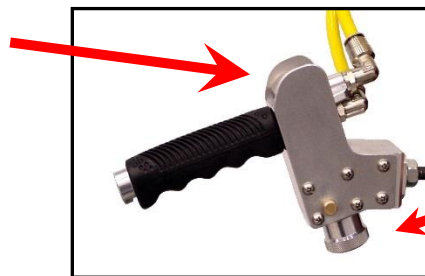

Adjustment knob

YOU ARE NOW READY TO USE YOUR HANDLING ARM.

CAUTION

When not in use, the holding device must be positioned at its highest position. This prevents movement of the holding device when the air is turned off.

During operation, the cable must always be under tension.

Holding the lowering command without tension on the cable, can damage the it.

RIGHT



WRONG



Cable Replacement Procedure

1. REPLACING THE OLD CABLE

- a) Unhook the suction device. **Do not disconnect the air.**
- b) Cut the wire from the end of the beam. **Secure the pulley block**

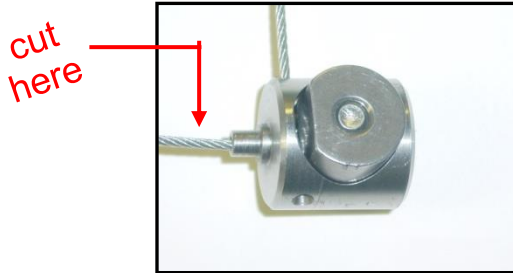

- c) Pull out the wire clamp from the end of the beam and cut the wire between the cap and the clamp. Pull the wire from the pulleys and let it hang down the column.
- d) Back up the safety set screw in the beam at the top of the column.
- e) Unclamp the hose from the column.



- f) With a "fork lift", lift the beam approximately 6 inches from the top of the column.

You may need to pry the beam up from the bearing

Make sure that the safety set screw is well back up.



- g) Move the beam sideways or lower it to the ground. **(optional)**

Make sure the wire does not tangle.

i) ***If required***, set the beam down and replace the pulley bloc.

Unscrew the 3 bolts.

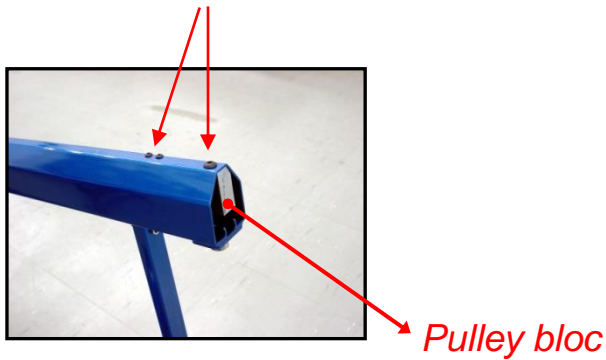

2. INSTALLING THE NEW CABLE

a) Using the control handle on the suction device, raise the piston to the top of the column.

Pull the cable out as the piston moves up

b) When the piston reaches the top, hold the button on the control handle for a few seconds to ensure the piston is firmly against the top.

c) With the special key, unscrew the old cable from the piston.

d) Secure the new wire onto the piston.

If the piston turns, simply apply more pressure to the piston using the control handle.



e) Remove the key and the wire from it.

Let the wire hang loose beside the column.

g) Using the control handle, lower the piston *slowly* to the bottom.

**** Make sure the wire is not tangled !!!**

YOU ARE NOW READY TO INSTALL THE BEAM

3. INSTALLATION OF THE BEAM

a) Hold the beam horizontally at 4 feet off the floor and the pivot end 1 foot from the post.



b) Thread the wire through the pivot bushing, around the pulley and let it hang between the diagonal braces

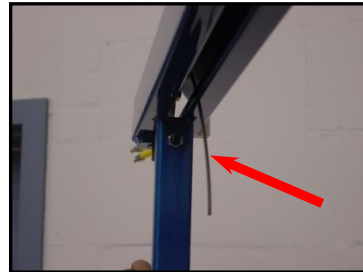
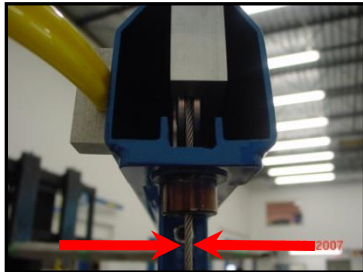

c) Lift the horizontal beam 2" above the top of the column, pulling the slack from the cable.

d) Position and lower the beam so that the pivot bushing sets onto the bearing in the top of the column.

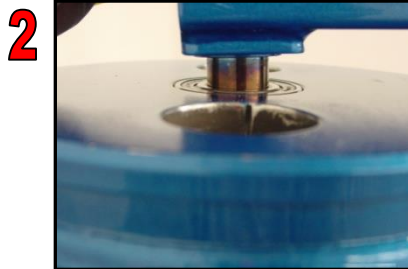
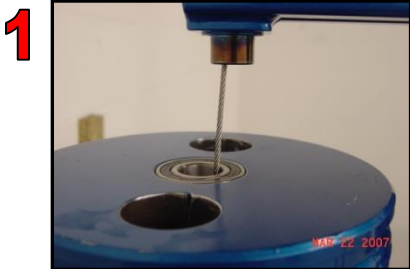

- f) Secure the lock screw on the vertical brace at the top of ccolumn leaving 1/32" of clearing between the diameter and the screw.



- g) Thread the wire through the pulley buggy and pulley block.

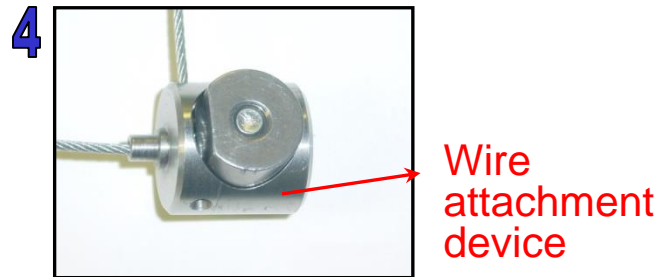
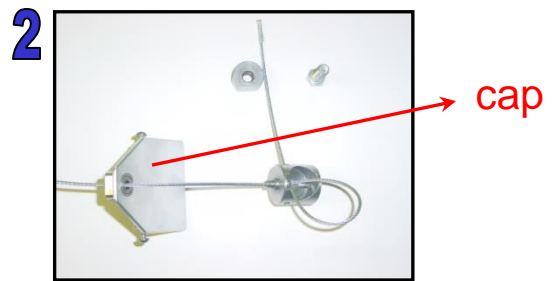
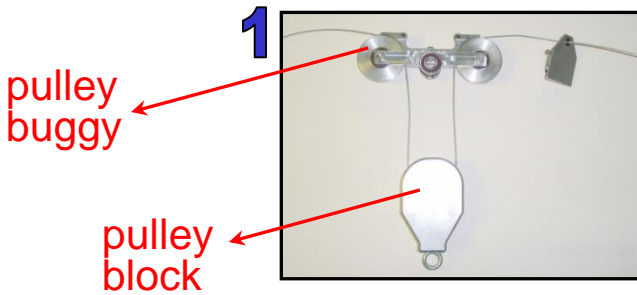

h) Insert the buggy in the horizontal beam.

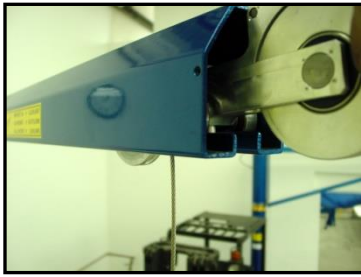

Make sure that the pulley block is supported.

i) Tighten the cap at the end of the horizontal beam.

j) Adjust the wire length by pulling it through the wire lock so that the pulley block is between the diagonal braces at their lowest point.



k) Tighten the wire lock screw.



l) Hang the suction cup on the pulley block.

FOR MORE INFORMATION

CONTACT US AT :

450-589-3378

Delaney
TECHNOLOGIES INC

DELANEY TECHNOLOGIES INC.

79, rue de l'Industrie

L'Assomption, Québec, J5W 2T9

Phone : (450) 589-3378 Fax : (450) 589-7370

info@delaneytechnologies.com